

Healing of double oxide film defects in A356 aluminium melt

Majid Aryafar · Ramin Raiszadeh ·
Alireza Shalbazadeh

Received: 21 January 2010 / Accepted: 8 February 2010 / Published online: 19 February 2010
© Springer Science+Business Media, LLC 2010

Abstract The possibility of the bonding of the two layers of a double oxide film defect when held in liquid A356 Al alloy was investigated. The defect was modelled experimentally by maintaining two aluminium oxide layers in contact with each other and the atmosphere trapped between them in the A356 liquid alloy for varying lengths of time of between 30 s and 48 h. Any changes in the composition and morphology of these layers were studied by SEM, EDX and XRD. The results showed that the two layers of a double oxide film defect might bond to each other by two different mechanisms, one during the transformation of Al_2O_3 to MgAl_2O_4 spinel in relatively short holding times, which would cause the layers to bond at several points and the other during the gradual transformation of spinel to MgO in longer times, which would cause strong bonding between the layers. It was shown that any bonding can take place essentially only after the oxygen and nitrogen of the atmosphere within the defect are consumed.

Introduction

Aluminium alloy castings are now becoming commonplace in highly demanding safety-critical applications in the automotive and aerospace industries. It is, therefore, imperative that internal defect structures and potential failure mechanisms are fully understood. A common casting defect with a random nature that significantly reduces the mechanical properties, and especially the reliability of Al alloys, is the double oxide film defect [1].

This defect forms when the surface oxide layer on the melt becomes submerged into the bulk liquid metal due to surface turbulence, as a doubled over oxide film with some gas from the local atmosphere (presumably predominantly air) trapped between the two unwetted oxide layers [1]. This leads to a crack in the solidified casting that not only reduces the mechanical properties of the casting, but also could act as an initiation site for the formation of other defects, such as hydrogen pores [2, 3] and Fe-rich phases [4].

It was suggested, by Nyahumwa et al. [5, 6], that a double oxide film defect could consume its internal atmosphere of oxygen and nitrogen. It was proposed that this process would occur after an incubation time due to a transition from amorphous to γ or α - Al_2O_3 , which would result in stresses in the film and the formation of cracks, bringing the internal atmosphere and the melt into contact. The consumption of the internal atmosphere has been recently verified by Raiszadeh and Griffiths [7] who monitored the change with time of the volume of a trapped air bubble in different Al alloy melts using real-time X-ray radiography, although they found no incubation time before the start of the consumption of the internal atmosphere. A semi-empirical mathematical model of the reduction in volume of the air bubble in the melt was

This article is dedicated to the founder of Kerman University, Mr. Alireza Afzalipour, on the occasion of the centenary of his birth.

M. Aryafar · R. Raiszadeh (✉) · A. Shalbazadeh
Department of Metallurgy and Materials Science, School
of Engineering, Shahid Bahonar University of Kerman,
Jomhoori Eslami Blvd., Kerman, Iran
e-mail: rraiszadeh@yahoo.com

M. Aryafar · R. Raiszadeh
Materials Department, International Center for Science, High
Technology and Environmental Sciences, Mahan, Kerman, Iran

developed [8] and applied to the case of a double oxide film defect, suggesting that it should consume its internal atmosphere of oxygen and nitrogen within times of a few seconds to 2 min, depending on assumptions about its initial size.

It was further speculated [5] that as the reaction proceeds and the internal gas volume decreases, the sides of the film defect would be forced into contact. However, argon (of which air contains approximately 1 vol.%) is insoluble and unreactive in Al and will remain between the two oxide layers. Once the two unwetted sides of the double oxide film defect are in contact, there is a possibility that they could bond together, at least at some points, due to the changes that might occur in the nature of the oxide layers with time. The defect might be then partially deactivated and its deleterious effect as a crack might be reduced. No evidence for this hypothesis has been presented to date.

It was shown by Impey et al. [9] that the presence of Mg in liquid Al greatly enhances the rate of oxidation. These researchers described the mechanism of oxidation of Al–(1–5 wt%) Mg alloys as follows.

‘Amorphous’ γ -alumina is the first oxide layer that forms instantaneously on the Al–Mg alloys at 750 °C. After 5 min, crystalline MgO (or MgAl_2O_4 , if the local concentration of Mg in the melt is low) develops beneath this layer. The growth of these oxide crystals beneath the continuous ‘amorphous’ layer results in considerable stress, primarily due to volume change, and causes the amorphous layer to fail. The fresh liquid metal then exudes through the ruptured oxide to the melt surface, a consequence of the wetting of alumina by liquid aluminium and aluminium-based alloys [10]. The exuded metal structure is then enveloped in a rapidly formed ‘amorphous’ oxide film and is described as an oxide growth. This process repeats and further growths take place.

The main objective of the work reported here is to investigate the possible healing mechanism for double oxide film defects in the A356 Al alloy (containing about 0.3 wt% Mg). For this purpose, two aluminium oxide layers in contact with each other were maintained in the A356 liquid alloy for varying lengths of time and any changes in the composition and morphology of these layers were studied by scanning electron microscopy (SEM), energy dispersive X-ray analysis (EDX) and X-ray diffraction (XRD) after the two layers were pulled apart after solidification.

Experimental procedure

A356 liquid metal, with the composition shown in Table 1, was prepared in a resistance-heated furnace and poured

Table 1 The chemical analysis of the A356 alloy used in the experiments

Si	Fe	Cu	Mn	Mg	Zn	Ni	Pb	Al
7.30	0.21	0.11	0.009	0.30	0.08	0.006	0.01	Bal

into silica sand moulds with 5% sodium silicate and CO_2 gas as a binder in the shape of bars. The bars were machined to dimensions of 100 mm in length and 19 mm in diameter. Two bars were then put in a seamless extruded steel tube (which is made especially for gas industries) with dimensions of 210 mm in length and 20 mm in internal diameter (Fig. 1). The bases of the bars that were in contact with each other in the steel tube were polished to 9 μm before the bars were inserted in the tube, so that the oxide layers that naturally formed on them resemble the two layers of a newly formed double oxide film defect.

The steel tube was then transferred to a cylindrical electric furnace with a sliding door at the top. The temperature of the furnace was set to 750 °C and the Al bars melted in the tube in 420 s. The melting time of the bars was measured in a separate experiment using a K-type thermocouple (with wire diameter of 0.3 mm) inserted at the middle of the steel tube. The melting caused the material to expand, but due to the difference between the diameter of the bars and the internal diameter of the tube, the upper level of the melt descended about 10 mm during the melting. The Al bars were held in the liquid state for varying lengths of time between 30 s and 48 h before the steel tube was raised in the furnace and held at the upper part of the heating chamber, with the door of the furnace left open to let the liquid metal inside the tube to solidify at

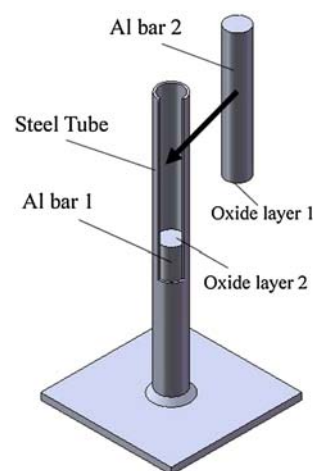

Fig. 1 Schematic illustration of the steel tube and the two Al bars inserted in it. After melting, the oxide layers 1 and 2 and the atmosphere trapped between them represented a double oxide film defect in a liquid Al alloy

a relatively slow rate (in about 40 s). The slow solidification of the metal was essential to prevent any thermal cracks from forming on the two oxide layers inside the melt.

The oxide layer that formed naturally over the solid Al bars remained intact during melting. The two oxide layers at the base of the two bars, which were in contact with each other in the steel tube, did not float away during the experiment, but moved along with the material during the expansion and contraction of the metal during its melting and solidification. These two oxide layers, with the atmosphere trapped between them, represented a double oxide film defect in this experiment, and, hence, the trapped atmosphere between the layers should not have any leak path to the ambient atmosphere. The only possible leak path from the trapped atmosphere to the outside was through the gap between the oxide layer around the Al bars and the wall of the steel tube. This leak path was eliminated by removing the oxide layer around the top of the upper Al bar with a sharp tool as soon as the melting of the Al bars was completed. The subsequent OM and SEM studies of the cross-section of a solidified Al sample inside the steel tube confirmed the complete wetting of the wall of the steel tube at the top of the upper bar by the Al melt and the elimination of the leak path from the atmosphere trapped between the two oxide layers to the ambient atmosphere. In some experiments, this leak path was left intact to study the effect of the continuous presence of air between the two oxide layers.

It should be noted that as the oxide layer around the Al bars did not wet the tube wall (except the area at the top of the upper bar, where the oxide layer around the bar was removed deliberately), the atmosphere trapped between the two oxide layers was extended through the gap between the bars and the tube wall to the top of the upper bar, but did not have any connection to the ambient atmosphere.

After solidification, the steel tube was cut and the Al bars were removed from it. In some experiments, the

bonding that formed between the two oxide layers during the experiment joined the two bars to each other. In this case, the two oxide layers were separated by pulling the two Al bars apart using a Zwick 1484 tensile testing machine with a strain rate of 1 mm min^{-1} . The surfaces of these two oxide layers were then examined using optical microscopy, a Camscan Scanning Electron Microscope fitted with an Oxford Inca EDX for microanalysis and an Xpert X-ray diffraction (XRD) device.

Each experiment was repeated at least three times to confirm the repeatability of the results.

Results

30 s holding

Figure 2 shows a photograph of the two oxide layers that were held in the liquid A356 Al for 30 s. The two layers were bonded to each other at a few points across the surface. Some of these bonding points are marked on the figure by arrows. The bonds were not strong (see Fig. 3) and the two bars detached easily from each other after the bars were removed from the steel tube.

The SEM micrograph from the surface of this specimen, shown in Fig. 4, showed a wrinkled oxide layer with several rose-shaped protrusions. The EDX study of a more highly magnified micrograph of this region, shown in Figs. 5 and 6, revealed that the liquid metal exuded from the centre of these protrusions. Despite this discontinuity, the oxide layer appeared to be dense and continuous.

The diffraction pattern obtained from the oxide layer is shown in Fig. 7. This pattern confirmed the presence of MgAl_2O_4 spinel in the layer, corresponding to the occurrence of the main peak of this phase at $2\theta = 36.65^\circ$. The peaks associated with Al_2O_3 appeared neither in the

Fig. 2 Photograph of the oxide layers that were held in the liquid metal for 30 s. Two of the bonded points are shown by arrows on both sides



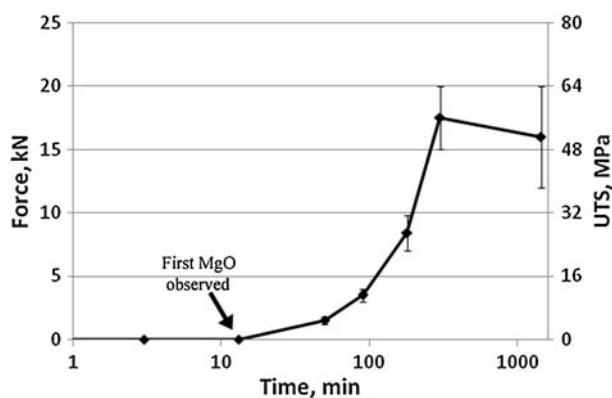

Fig. 3 The force required for the separation of the two Al bars after they were held in the liquid metal for different lengths of time

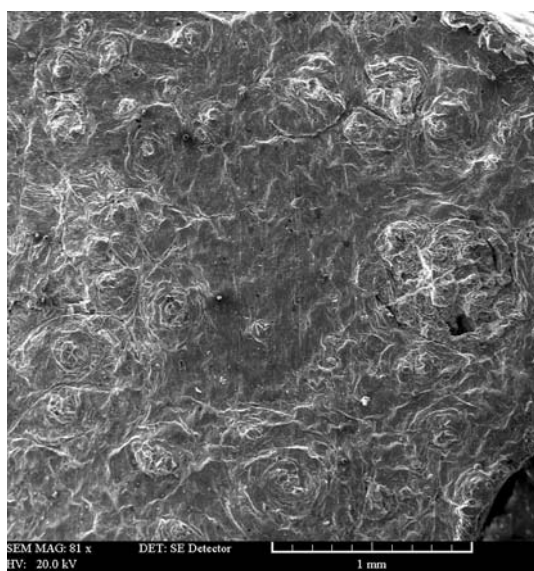

Fig. 4 SEM micrograph of the surface of the oxide layer shown in Fig. 2

spectrum obtained from this specimen nor the one obtained from the polished surface of an A356 sample, which showed only the presence of Al and Si. Al_2O_3 is the first oxide that forms on the surface of an Al-0.5 wt% Mg alloy [9]. Therefore, the absence of the peaks associated with this oxide in the spectrum obtained from an A356 sample, or other samples obtained in this research, could be due to the extreme thinness of this layer and is not evidence for the absence of this oxide in the sample.

13 min holding

The photograph of the oxide layers that were held in the liquid metal for 13 min, shown in Fig. 8, is almost the same as those that were held for 30 s (Fig. 2), except the two layers are bonded to each other at more points.

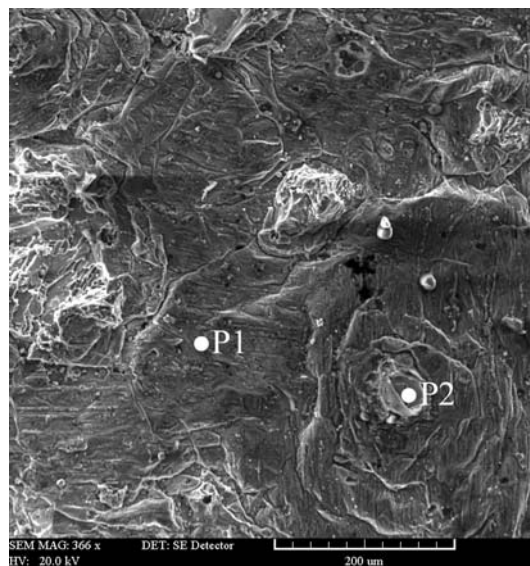

Fig. 5 A higher magnification of the SEM micrograph shown in Fig. 2. The EDX spectra obtained from the points P1 and P2 are shown in Fig. 6

However, the force needed to separate the two Al bars was still negligible (Fig. 3).

Figure 9 shows an SEM micrograph of the surface of the oxide layer presented in Fig. 8. This figure shows that the wrinkled, spinel-containing oxide layer started to transform to a flat and porous layer. Figure 10 shows a higher magnification of the transformed part of the layer. The EDX analysis of this layer (shown in Fig. 11) revealed the identity of the newly formed porous layer to be MgO, which emerged from the spinel layer. The identity of this new layer was also confirmed by XRD (shown in Fig. 12, with the occurrence of the main peak of MgO at $2\theta = 42.82^\circ$).

50 min holding

The photograph of the surfaces of the oxide layers that were held in the liquid metal for 50 min (Fig. 13) show a few larger areas of bonding, as well as the point bonding that was observed in the previous specimens. This was the first experiment in which the separation of the two Al bars was not possible except with the aid of the tensile test machine. The average force needed to separate the Al bars was about 1.5 kN (Fig. 3).

Dark patches appeared at the middle and the outer edge of the layer. This was attributed to the thickness of the MgO, which, based on the XRD patterns obtained from the darker and lighter sections of the oxide layer, was greater in the darker areas. These patterns (not presented in this article for brevity) also confirmed the presence of both spinel and MgO in the layer, which revealed that the

Fig. 6 The spectra obtained from the points (a) P1 and (b) P2 given in Fig. 5. P1 contained 11.2 and 1.01 wt% O₂ and Mg, respectively. These concentrations at P2 were measured to be 0.2 and 0.0 wt%, respectively

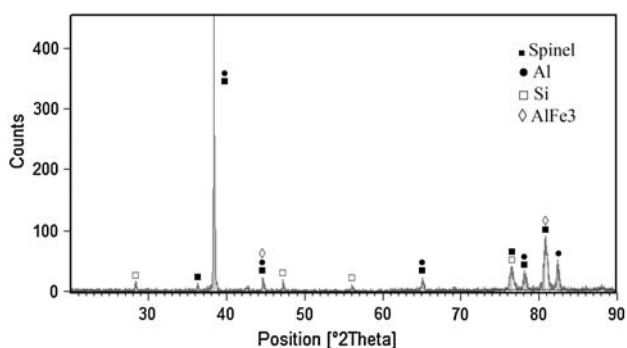
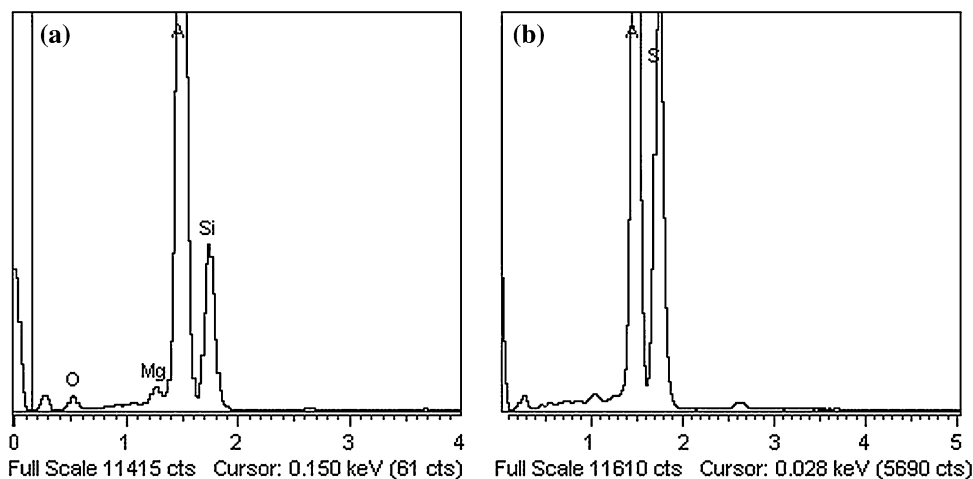

Fig. 7 XRD spectrum obtained from the surface of the oxide layer shown in Fig. 2

transformation of the spinel to MgO that had started at about 13 min was still in progress. The SEM and EDX studies (see Fig. 14) also confirmed the presence of a mixture of spinel and MgO in the oxide layer.

Figure 15 shows an area at which the two oxide layers were bonded to each other and were then separated during the pulling of the two Al bars with the tensile test machine.

Fig. 8 Photograph of the oxide layers that were held in the liquid metal for 13 min



Figure 16 shows a crack that formed in the oxide layer in some stage, perhaps during the cooling or solidification of the sample. The absence of the oxygen peak in the EDX spectrum obtained from the material in the crack (shown in Fig. 17a) confirmed that the oxygen in the trapped atmosphere between the two oxide layers was consumed before this crack was formed.

Holding times of more than 90 min

Figures 18, 19 and 20 show photographs of the surfaces of the oxide layers that were held in the liquid metal for 1.5, 3 and 5 h, respectively. The amount of MgO as well as the area of the bonded surfaces between the two oxide layers and the force needed to separate the two Al bars increased gradually with time. Point bonding was also observed at many points throughout the surface. The bonding was almost complete in the sample that was held in the liquid metal for 5 h (Fig. 20) and the amount of bonding and the force needed to separate the Al bars did not increase after this holding time.

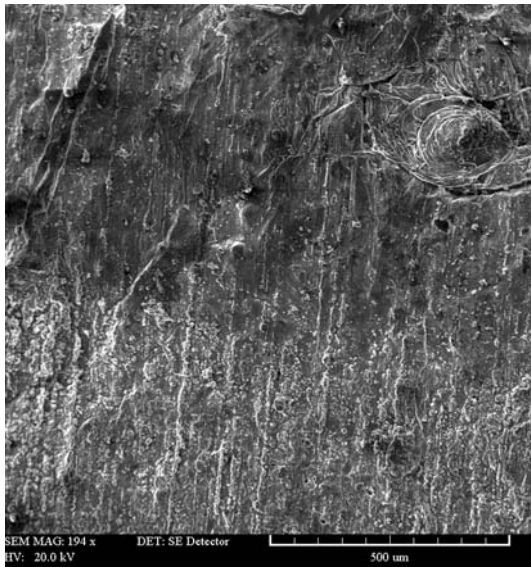

Fig. 9 SEM micrograph of the surface of the oxide layer shown in Fig. 8, showing the transformation of the oxide layer from spinel to MgO

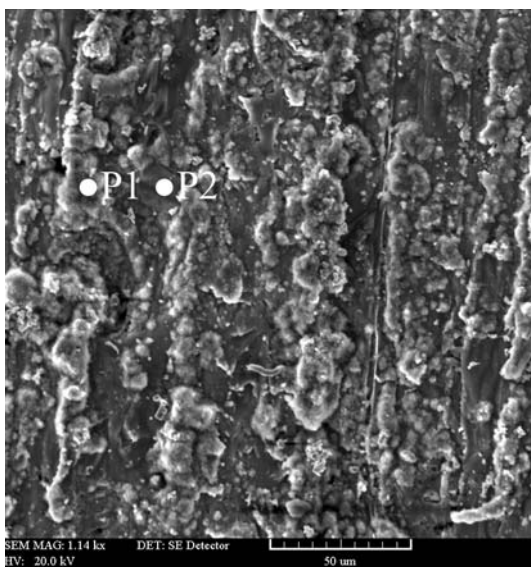

Fig. 10 A higher magnification of the lower part of Fig. 9, showing the porous nature of the MgO layer. The EDX spectra obtained from points P1 and P2 are shown in Fig. 11

The effect of the continuous presence of air between the two oxide layers

Generally, in the experiments in which the connection of the atmosphere between the oxide layers to the ambient atmosphere was not eliminated, the transformations that occurred in the oxide layers were the same as those previously described.

Figure 21 shows a photograph of the surfaces of the oxide layers that were held in the liquid metal for 24 h and

the path between the oxide layers and the ambient atmosphere was not eliminated. The white area on the oxide layer was identified by EDX to be MgO (Fig. 22). The very low concentration of Al on the white area (about 1.77 wt%) revealed that the transformation of spinel to MgO was completed in this area and that the MgO layer that formed was thick enough to prevent the Al underneath from being detected by EDX. However, despite the drastic growth of MgO in the long holding time of 24 h, no bonding occurred between the two layers. The protrusion of liquid Al through the oxide layer was also observed at several points, but this could not produce any point bonding between the two oxide layers.

Most of the spinel was transformed to white areas of MgO when the oxide layers were held in the melt for 48 h (Fig. 23). However, bonding was still not observed between the two layers, except for one very small area (noted by arrows on Fig. 23).

Discussion

The results showed that the presence of air between the two oxide layers prevented the layers from contacting each other and, hence, regardless of the holding time, prevented any bonding from taking place between the layers (see Figs. 21, 23). Therefore, the bonding observed in the experiments in which the leak path from the trapped atmosphere to the ambient atmosphere was eliminated implied that the oxygen and nitrogen of the trapped atmosphere were consumed and, therefore, the two oxide layers were in contact with each other, at least at several points.

Based on the consumption rates of oxygen and nitrogen reported in the literature (1.1×10^{-6} [10] and 1.88×10^{-6} [8] mol s⁻¹ m⁻², respectively), and assuming the gap between the two oxide layers to be about 40 μm [1], the oxygen and nitrogen within the trapped atmosphere can be estimated to be consumed in about 20 and 70 s, respectively. This calculation is, however, based on two stagnant oxide layers, the parabolic thickening of which (at 750 °C) takes place by the movement of either metal ions inwards or oxygen atoms outwards through the layers [11]. Raiszadeh and Griffiths [7] suggested that the cracks that form on the oxide layers when the layers move in the liquid metal during melting might accelerate these consumption rates, and the two gases within the trapped atmosphere might be consumed in shorter times.

The initial type of the oxide layers (before the start of the experiment) could not be detected by XRD, due to the extreme thinness of the layers. However, the first oxide formed on the Al-(1–5 wt%) Mg alloys was determined in other works [9, 12] to be an amorphous Al₂O₃ layer.

Fig. 11 The EDX spectra of points (a) P1 and (b) P2 given in Fig. 10. The composition (all wt%) at P1 was measured to be 11.4% Al, 26.7% Mg, 40.7% O and 15.4% Si (MgO) and at P2 to be 82.4% Al, 2.43% Mg, 12.2% O and 2.0% Si (spinel)

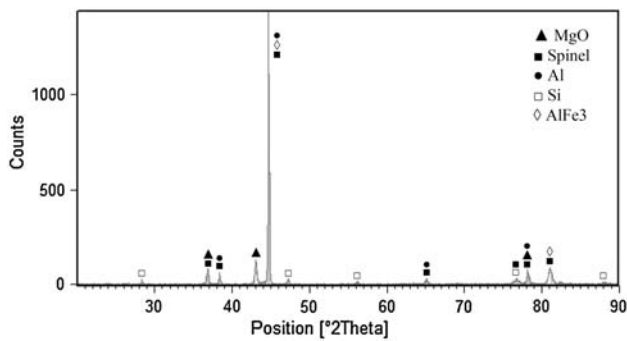
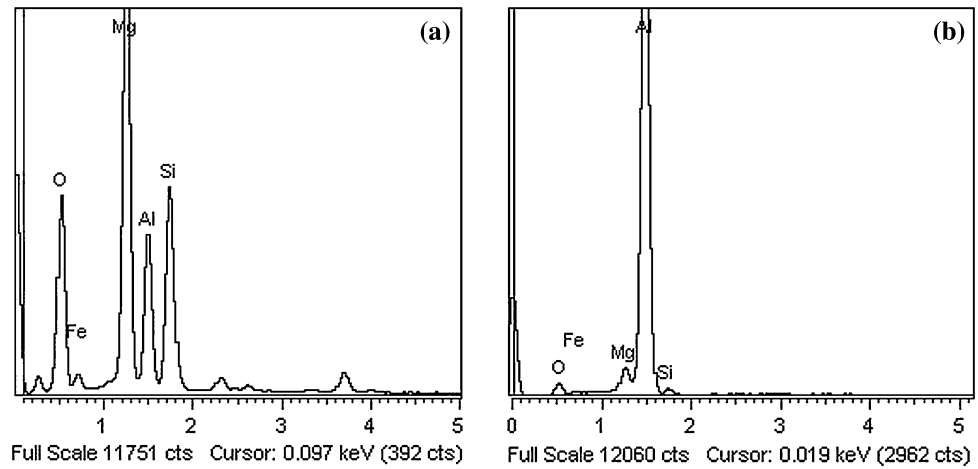

Fig. 12 XRD spectrum obtained from the surface of the oxide layer shown in Fig. 8

This amorphous alumina layer started to transform to spinel immediately after (or perhaps during) the melting of the Al bars. The three possible chemical reactions for the formation of spinel, as well as their free energies of formation (for the reaction of 1 mol of Mg), are shown in Table 2. The occurrence of Reactions 1 and 2 is possible only before the partial pressure of the oxygen in the trapped atmosphere falls below a critical level, which, according to

the estimated consumption times, occurs within 20 s after the bars are melted. Therefore, despite their favourable free energies of formation, Reaction 3 is the main chemical reaction by which the amorphous Al_2O_3 transforms to spinel.

This transformation, which occurs at the melt-oxide interface [9], is associated with a volume expansion of about 18% (calculated using the molecular weights and densities of the oxides involved [13] and Reaction 3). This volume change results in a local build up of stress and causes the alumina layer to fail. The fresh A356 melt could then exude through the ruptured oxide to form the rose-shaped protrusions observed in Figs. 4 and 5. Such protrusions were also observed by Impey et al. [9] in Al–Mg alloys.

It has been reported in the literature [14], using a sessile drop technique, that aluminium does not wet alumina below 900 °C. Further studies (for example [10, 15]) revealed that in the sessile drop experiments it is the presence of a thin surface alumina layer that accounts for the non-wetting of alumina by aluminium and, once this oxide layer is eliminated, Al melt can wet the alumina. Therefore, after the oxygen and nitrogen of the trapped

Fig. 13 Photograph of the oxide layers that were held in the liquid metal for 50 min



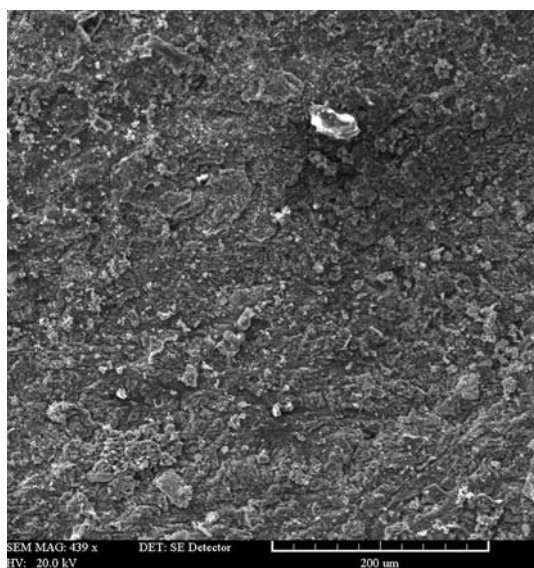

Fig. 14 SEM micrograph of the surface of the oxide layer shown in Fig. 13 (darker area), showing an MgO layer grew on the spinel layer. The EDX spectrum obtained from this area determined the concentration of the present elements (all in wt%) to be 36.2% Al, 11.9% Mg, 32.7% O and 12.6% Si (spinel + MgO)

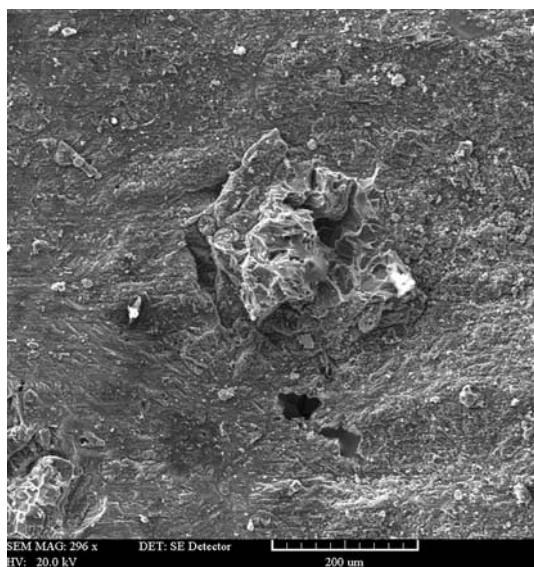

Fig. 15 An area at which the two oxide layers were bonded to each other and were then separated by pulling the two Al bars apart using the tensile test machine

atmosphere are consumed, the liquid Al that exudes through the rose-shaped protrusions could wet the internal wall of the opposite oxide layer and form the point bonding that was observed in all the experiments.

Figure 3 shows that the start of the increase in the strength of the bonding between the two oxide layers corresponds to the first MgO observed in the microstructure (at the holding time of 13 min). The three possible

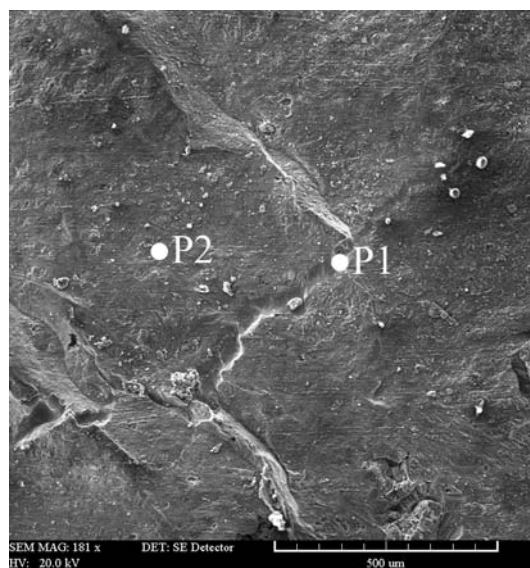

Fig. 16 A crack that was introduced to the oxide layer in some stage, perhaps during the cooling or solidification of the specimen. The EDX spectra obtained from the points P1 and P2 are shown in Fig. 17

chemical reactions for the formation of MgO, along with their free energies of formation (for the reaction of 1 mol of Mg), are shown in Table 2. Since all the oxygen of the trapped atmosphere should be consumed by this time, Reaction 4 could not take place. Reaction 5 is not likely either, since, for 1 mol of Mg, the formation of spinel through the reaction of Mg and alumina (Reaction 3) is thermodynamically more favourable than the formation of MgO (Reaction 5). Levi et al. [16] also pointed out that Reaction 5 is unlikely when the Mg content of the alloy is less than 4 wt%. Therefore, Reaction 6 is the only feasible chemical reaction that could take place in the holding time of 13 min, when all of the alumina should have transformed to spinel.

After the oxygen and nitrogen of the trapped atmosphere were consumed, the two unwetted sides of the oxide layers would be in contact. This contact, however, would be imperfect due to the roughness of the solid oxide layers [17]. The liquid metals that might exude through the two porous MgO layers could join to each other and cause the bonding to take place between the layers. However, this process was shown to be rather slow, requiring at least 5 h to complete.

Extending the findings of this work to real double oxide film defects in the A356 alloy, it can be concluded that the defects could heal if held in the liquid metal long enough. This healing would be caused by two different mechanisms. The first one, in relatively short holding times of a few minutes, is due to the transformation of the alumina layer to spinel, which causes breakaway oxidation in the alumina layer and the exudation of liquid aluminium into

Fig. 17 EDX spectra obtained from points (a) P1 and (b) P2 given in Fig. 16. The composition (all wt%) at P1 was measured to be 79.8% Al, 0.0% Mg, 2.05% O and 18.13% Si (A356) and at P2 to be 69.07% Al, 4.14% Mg, 16.24% O and 9.54% Si (spinel + MgO)

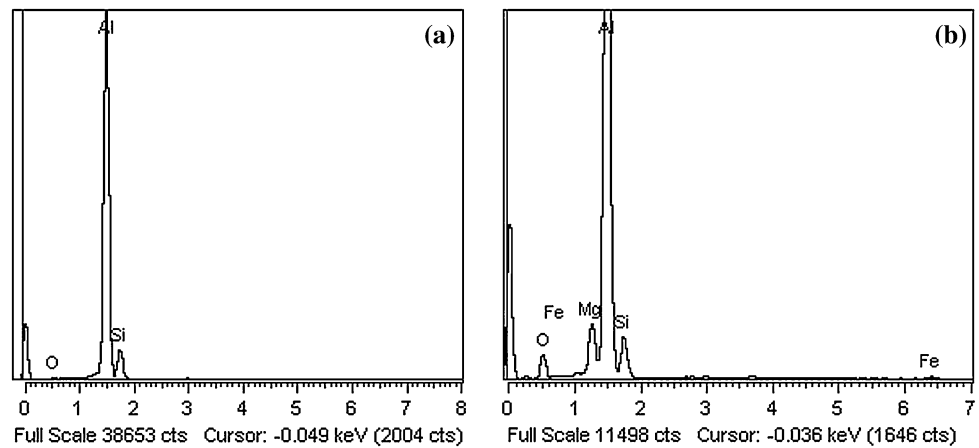

Fig. 18 Photograph of the oxide layers that were held in the liquid metal for 1.5 h



Fig. 19 Photograph of the oxide layers that were held in the liquid metal for 3 h



the gap between the two layers. If oxygen is not present in the gap, Al can wet the inner wall of the opposite oxide layer and create some point bonding. This bonding was shown not to be very strong, but might be able to reduce the deleterious effect of the oxide film defect as a crack.

The second bonding mechanism, which requires longer holding times, is due to the gradual transformation of

spinel to MgO. The liquid metals that exude through the porous MgO layers cause the two oxide layers to bond to each other strongly and may prevent the defect from acting as an initiation site for the formation of other defects, such as gas porosity.

Consideration of the estimated durations of the double oxide film defect atmosphere and typical solidification

Fig. 20 Photograph of the oxide layers that were held in the liquid metal for 5 h

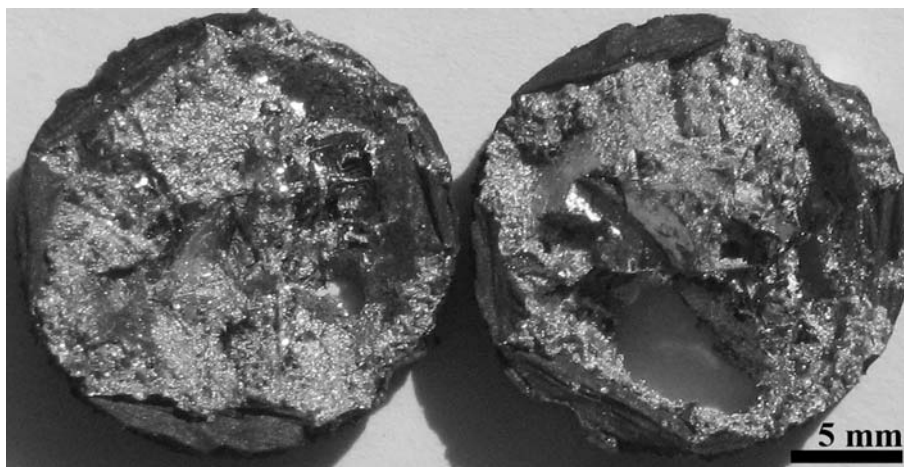

Fig. 21 Photograph of the oxide layers that were held in the liquid metal for 24 h and the connection of the atmosphere between the layers to the ambient atmosphere was not eliminated

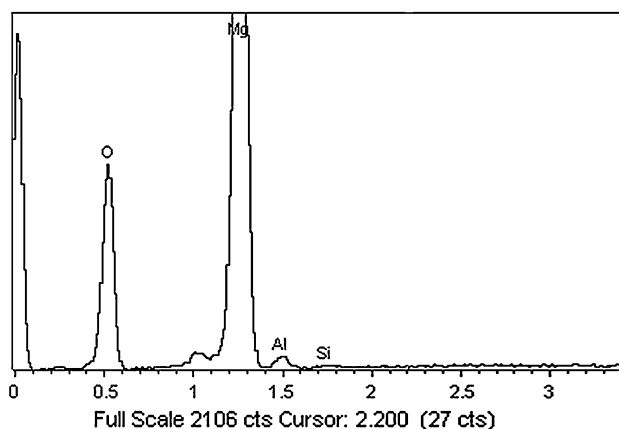

Fig. 22 EDX spectrum obtained from point P1 given in Fig. 21. The composition (all wt%) at P1 was measured to be 1.77% Al, 57.52% Mg, 40.71% O and 0.11% Si (MgO)

times of castings suggests that double oxide films may still be in the process of having their interior atmosphere consumed as the castings are solidifying. The presence of

oxygen or nitrogen in the gap between the two oxide layers was shown to prevent any bonding from taking place. If the metal is held in the liquid state for long enough, and the internal atmosphere of the oxide film defects is consumed, the surfaces may be joined together through the mechanisms described above. However, the kinetics of the reactions that were studied in this research (including the rates of consumption of oxygen and nitrogen in the trapped atmosphere within the oxide layers) might be different from those that actually occur when the double oxide film defects are involved and the bonding might occur faster or, perhaps, in longer times.

Conclusions

The results obtained in this work showed that the two oxide layers of a double oxide film defect might bond together if maintained in liquid A356 Al alloy for a long enough time. This bonding would be caused by two different mechanisms.

Fig. 23 Photograph of the oxide layers that were held in the liquid metal for 48 h and the connection of the atmosphere between the layers to the ambient atmosphere was not eliminated

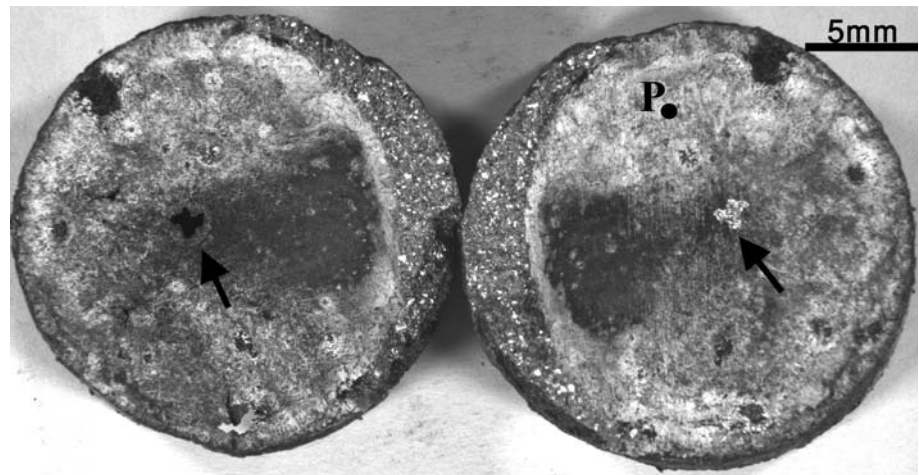

Table 2 The possible chemical reactions for the formation of spinel and MgO in the A356 melt

Number	Possible chemical reaction	ΔG at 1,000 K (kJ mol ⁻¹)
Formation of spinel		
1	$\{\text{Mg}\} + \langle \text{Al}_2\text{O}_3 \rangle + \frac{1}{2}[\text{O}_2] = \langle \text{MgAl}_2\text{O}_4 \rangle$	-525.5
2	$\{\text{Mg}\} + 2\{\text{Al}\} + 2[\text{O}_2] = \langle \text{MgAl}_2\text{O}_4 \rangle$	-188.6
3	$\{\text{Mg}\} + \frac{4}{3}\langle \text{Al}_2\text{O}_3 \rangle = \langle \text{MgAl}_2\text{O}_4 \rangle + \frac{2}{3}\{\text{Al}\}$	-71.7
Formation of MgO		
4	$\{\text{Mg}\} + \frac{1}{4}[\text{O}_2] = \frac{1}{2}\langle \text{MgO} \rangle$	-246.5
5	$\{\text{Mg}\} + \frac{1}{3}\langle \text{Al}_2\text{O}_3 \rangle = \langle \text{MgO} \rangle + \frac{2}{3}\{\text{Al}\}$	-39.3
6	$\{\text{Mg}\} + \frac{1}{3}\langle \text{MgAl}_2\text{O}_4 \rangle = \frac{4}{3}\langle \text{MgO} \rangle + \frac{2}{3}\{\text{Al}\}$	-28.3

One, which occurs at holding times of a few minutes, is due to the transformation of alumina to spinel and causes the two layers to bond to each other at several points. This bonding is not particularly strong but might reduce the deleterious effect of the defect as a crack. The other happens during the gradual transformation of spinel to MgO in holding times of 13 min or more. This transformation causes a strong bonding between the two oxide layers and may prevent the defect from acting as an initiation site for the formation of other defects, such as gas porosity. However, any bonding can take place essentially only after the oxygen and nitrogen of the atmosphere within the defect is consumed.

Acknowledgement The authors would like to gratefully thank the “International Center for Science, High Technology and Environmental Sciences”, Mahan, Kerman, Iran, who supported this project

under the Contract No. 1/1864, and Dr. W. D. Griffiths from the University of Birmingham for helpful discussions.

References

- Campbell J (2003) Castings, 2nd edn. Butterworth-Heinemann, Oxford
- Fox S, Campbell J (2000) Scripta Mater 43:881
- Griffiths W, Raiszadeh R (2009) J Mater Sci 44:3402. doi: 10.1007/s10853-009-3450-7
- Cao X, Campbell J (2003) Metall Mater Trans A 34A:1409
- Nyahumwa C, Green N, Campbell J (1998) AFS Trans 58:215
- Nyahumwa C, Green N, Campbell J (2001) Metall Mater Trans A 32A:349
- Raiszadeh R, Griffiths W (2006) Metall Mater Trans B 37B:865
- Raiszadeh R, Griffiths W (2008) Metall Mater Trans B 39B:298
- Impey S, Stephenson D, Nicholls J (1990) In: International conference on the microscopy of oxidation. Inst of Metals, Cambridge University, pp 238–244
- Impey S, Stephenson D, Nicholls J (1988) Mater Sci Tech-Lond 4:1126
- Sleppy WC (1961) J Electrochem Soc 108:1097
- Tenorio JAS, Espinosa DCR (2000) Oxid Met 53:361
- Brandes EA, Brook GB (1999) Smithells metals reference book, 7th edn. Butterworth-Heinemann, Oxford
- Carnahan RD, Johnson LT, Li CH (1958) J Am Ceram Soc 41:343
- John H, Hausner H (1986) J Mater Sci Lett 5:549
- Levi CG, Abbaschian GJ, Mehrabian R (1978) Met Trans 9A:697
- Shimizu K, Brown GM, Kobayashi K, Skeldon P (1998) Corros Sci 40:557